



DAVIDSONS
HOMES

THE LINCOLN
4 BEDROOM
DETACHED
HOME

An exclusive opportunity to own
a desirable new property that
provides comfortable living with
craftsmanship of the highest calibre.

DH400V-2
[1181]

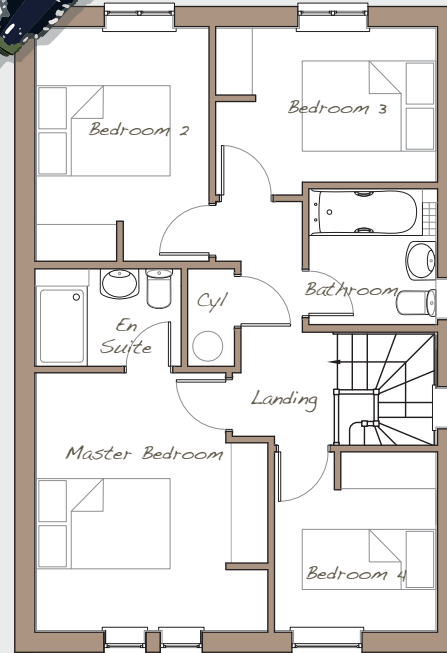
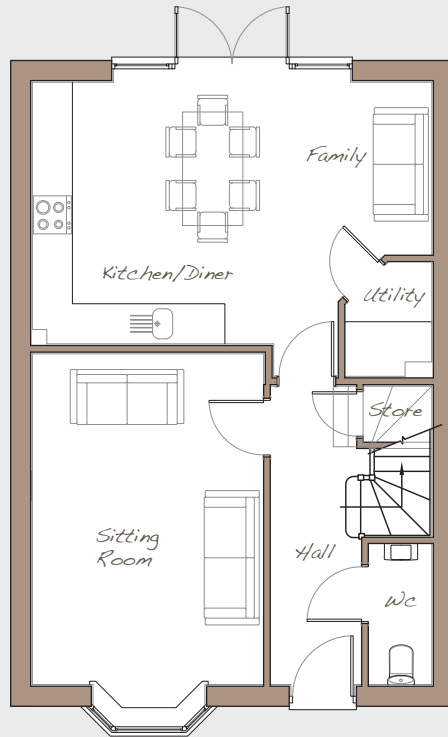
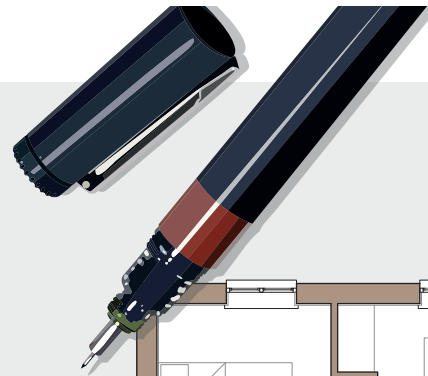

Ground Floor

Sitting Room	3460	x	5295	11'4"	x	17'4"
Kitchen/Family/Diner	5975	x	3910	19'6"	x	12'8"
Utility	1295	x	1710	4'2"	x	5'6"
WC	2110	x	945	6'9"	x	3'1"

First Floor

Master Bedroom	3460	x	3855	11'4"	x	12'6"
En Suite	2160	x	1455	7'1"	x	4'8"
Bathroom	1895	x	2030	6'2"	x	6'7"
Bedroom 2	2580	x	3485	8'5"	x	11'4"
Bedroom 3	3295	x	2495	10'8"	x	8'2"
Bedroom 4	2415	x	2670	7'9"	x	8'8"

This is an artistic interpretation, therefore variations in finishes and exact layout may not be accurate. Please ask your Sales Manager for complete specifications. Images are for illustration purposes only. Please be aware that a tolerance of 50mm should be taken into consideration for plasterboard and brickwork. Measurements provided are maximum measurement information for the space.



DAVIDSONS HOMES

THE LINCOLN FLOORPLANS



Davidsons Group.
Wilson House, Leicester Road,
Ilstock, Leicestershire, LE67 6HP

T: 01530 261 444

F: 01530 267 140

www.davidsonsgroup.co.uk